

# P5-20...L120-11

## Model: C12 PLUS

### **en** Assembly and Operating Instructions

## Sun protection drives with integrated radio transceiver

Important information for:

- Fitters / • Electricians / • Users

Please forward accordingly!

These instructions must be kept safe for future reference.

2010 301 142 0c 01/03/2024

Becker-Antriebe GmbH  
Friedrich-Ebert-Straße 2-4  
35764 Sinn/Germany  
info@becker-antriebe.com  
www.becker-antriebe.com



**BECKER**  
for you. forever.

## Table of contents

General .....	3
Warranty .....	3
Safety instructions .....	4
Instructions for the user .....	4
Instructions for installation and commissioning .....	4
Intended use .....	6
Assembling and disassembling the plug-in connecting cable .....	6
Assembly .....	7
Compatible Centronic transmitters .....	9
Explanation of functions .....	9
Commissioning with a CentronicPLUS transmitter .....	11
Establish programming mode .....	12
Programming the CentronicPLUS transmitter .....	12
Adding additional transmitters to the installation .....	13
Selection of the receiver for the setting mode .....	13
Checking that the running direction is correct .....	14
Intelligent installation management .....	15
Limit position status indicator .....	15
Setting the limit positions .....	15
Extended point to retracted point .....	15
Extended point to retracted stop .....	16
Changing the additional stop behaviour function .....	16
Changing the set limit positions .....	17
Setting the limit positions with Auto-Install .....	18
Deleting the limit positions .....	19
Intermediate positions I + II .....	20
Restoring the wireless memory of the tubular drive to factory settings .....	21
Commissioning with a Centronic transmitter .....	23
Intelligent installation management .....	24
Limit position status indicator .....	24
Programming the master transmitter .....	24
Checking that the running direction is correct .....	24
Setting the limit positions .....	25
Extended point to retracted point .....	25
Extended point to retracted stop .....	25
Changing the additional stop behaviour function with the master transmitter .....	26
Changing the set limit positions .....	26
Setting the limit positions with Auto-Install .....	27
Deleting the limit positions .....	28
Intermediate positions I + II .....	29
Programming additional transmitters .....	29
Deleting transmitters .....	30
Overwriting the master .....	30
Additional functions with CentronicPLUS / Centronic .....	31
Activating/deactivating the additional fabric untensioning function .....	31
Activating/deactivating the additional fabric tensioning function .....	32
Restoring the factory settings of the tubular drive .....	33
Local operation with a single button .....	34
Obstacle detection .....	34
Disposal .....	34
Maintenance .....	34
Technical data dia. 35 .....	35
Technical data dia. 45 .....	35
Technical data dia. 58 .....	36
Error messages .....	37
What to do if...? .....	37
Sample wiring diagram .....	38
Declaration of conformity .....	39

## General

These tubular drives are high-quality products with the following features:

- Optimised for sun protection applications
- Suitable for awnings and conservatory shades. Type "+" drives are specially designed for cassette awnings
- Individual, group and central radio control
- No need to run wires to a switch or relay control device
- Any combination of drive and transmitter possible
- Simple to set the limit positions with the transmitter
- Installation without stops possible (from extended point to retracted point)
- Two freely selectable intermediate positions can be set
- Flexible radio grouping; can be altered at any time with no need to install/uninstall
- Automatic detection of limit positions thanks to intelligent electronic system with stop systems
- The limit positions do not have to be reset: Changes in the shading solution are accommodated automatically when using stop systems.
- Considerably reduced stop load, and thus considerably reduced shading solution load
- Smooth operation of the system and the drive increases the service life
- For plug-in connecting cable

Please follow these Assembly and Operating Instructions when installing and setting up the device.



The date of manufacture comes from the first four digits of the serial number.

The numbers 1 and 2 indicate the year and the numbers 3 and 4 indicate the calendar week.

Example: 34th calendar week in 2020

Ser. No.:	2034XXXXX
-----------	-----------

### Explanation of pictograms

	<b>CAUTION</b>	CAUTION indicates a hazardous situation which, if not avoided, could result in injury.
	<b>ATTENTION</b>	ATTENTION indicates measures that must be taken to avoid damage to property.
		Denotes user tips and other useful information.

## Warranty

Structural modifications and incorrect installation which are not in accordance with these and our other instructions can result in serious injuries, e.g., crushing of limbs. Therefore, structural modifications may only be carried out with our prior approval and strictly in accordance with our instructions, particularly the information contained in these Assembly and Operating Instructions. Any further processing of the products which does not comply with their intended use is not permitted.

The end product manufacturer and fitter have to ensure that all the relevant current statutory, official and, in particular, EMC regulations are adhered to during utilisation of our products, especially with regard to end product manufacture, installation and customer advice.

## Safety instructions

The following safety instructions and warnings are intended to avert hazards and to prevent property damage and personal injury.

### Instructions for the user

#### General information

- The drive must be disconnected from its power source during cleaning and maintenance and when replacing parts.
- All work, including maintenance and cleaning, on electrical installations as well as other system parts must always be performed by trained technicians, in particular qualified electricians.
- Children from the age of 8 years and persons with reduced physical, sensory or mental capabilities or lack of experience and/or knowledge may use these devices, provided they are supervised or have been instructed in the safe use of the device, and have understood the hazards involved. Children must not play with the device.
- Systems have to be checked regularly by authorised specialists for wear and damage.
- Always put damaged systems out of operation immediately until they are repaired by an authorised specialist.
- Do not operate equipment if people or objects are within the danger zone.
- Observe the danger zone of the equipment during operation.
- Ensure that there is adequate clearance (at least 40 cm) between moving parts and adjacent objects.



#### Caution

##### Safety instructions for avoiding serious injuries.

- **Crushing or shearing points must be avoided or protected.**

### Instructions for installation and commissioning

#### General information

- Observe the safety instructions in EN 60335-2-97. Please note that this list of safety instructions is not exhaustive, since it would be impossible for the standard to include all sources of danger. For example, the design of the operated product, the way the drive works in the situation it is installed in or even the way the end product is mounted in the end user's place of use cannot be taken into consideration by the drive manufacturer.  
If any questions or uncertainties regarding the safety instructions contained in the standard arise, please contact the manufacturer of the part or end product in question.
- All applicable standards and regulations for electrical installation must be complied with.
- All work, including maintenance and cleaning, on electrical installations as well as other system parts must always be performed by trained technicians, in particular qualified electricians.
- Only use spare parts, tools and accessory devices which have been approved by the drive manufacturer.  
Unapproved third-party products or modifications to the system and its accessories represent a risk to your safety and the safety of others. This means that the use of unapproved third-party products, or modifications which have not been agreed with or approved by us, are prohibited. We do not accept liability for damage or injury arising from such actions.
- Position switch with OFF presetting within sight of the driven product, but away from moving parts, at a height of over 1.5 m. This must not be publicly accessible.
- Permanently mounted control devices must be positioned where they can be seen.
- Rated torque and duty cycle must be suitable for the requirements of the driven product.  
Technical data - rated torque and service life can be found on the type plate of the tubular drive.
- Hazardous moving parts of the drive must be installed at a height of over 2.5 m above floor level or any other surface from which the drive can be accessed.
- To ensure safe operation of the system after commissioning, the limit positions must be correctly set/programmed in.
- Drives with a H05VV-F connecting cable may only be used indoors.
- Drives with a H05RR-F, S05RN-F or 05RN-F connecting cable may be used both indoors and outdoors.
- To connect the drive to the driven part, solely mechanical accessory components made by the drive manufacturer from the current product catalogue may be used. The components must be installed in accordance with the manufacturer's instructions.

- If the drive is used for shading solutions in a specially marked area (e.g., escape routes, hazard zones, safety areas), compliance with all applicable regulations and standards must be ensured.
- Once the drive has been installed, the fitter must mark the used tubular drive in the “Technical data” chapter and make a note of the installation position.



#### **Caution**

##### **Safety instructions for avoiding serious injuries.**

- **When electrical or electronic equipment and units are operated, certain components, e.g., the power supply unit, are live. Physical injuries or damage to property can result in the event of unauthorised interventions or failure to heed warnings.**
- **Be careful when touching the tubular drive, as it heats up during operation for technical reasons.**
- **Before installation, shut down all lines and control devices that are not essential for operation.**
- **Crushing or shearing points must be avoided or protected.**
- **When installing the drive, all-pole disconnection from the mains with a contact gap of at least 3 mm per pole must be provided (EN 60335).**
- **If the mains connecting cable is damaged, it may only be replaced by the manufacturer. If the drive has a plug-in connecting cable, it must be replaced with the same type of mains connecting cable, which is available from the drive manufacturer.**

#### **Attention**

##### **Safety instructions for avoiding property damage.**

- **Ensure that there is adequate clearance between moving parts and adjacent objects.**
- **The drive must not be carried by the mains connecting cable.**
- **All latching connections and fastening screws on the brackets must be checked to ensure that they are secure.**
- **Ensure that nothing rubs against the tubular drive, such as shading solution attachments, screws, etc.**
- **The drive must be fitted horizontally.**

## Intended use

The type of tubular drive described in these instructions is intended solely for the operation of awnings and conservatory shades. It may only be used in networked systems if all the individual drives are exactly synchronised and reach the limit positions at the same time.

When mounting connection parts on the drive dia. 35 mm PXX/XX, only use screws EJOT Delta PT 40x12 WN 5454 Torx (9900 000 545 4).

For roller shutter applications, please use only the types of tubular drive designed for this purpose.

This type of tubular drive is designed for use in single systems (one drive per barrel).

The tubular drive must not be used in potentially explosive areas.

The connecting cable is not suitable for transporting the drive. Always carry the drive by the housing tube.

Other applications, uses and modifications are not permitted in order to protect the safety of the users and others, since these actions can impair the system's safety and carry the risk of personal injury and property damage. The drive manufacturer does not accept liability for damages or injury arising from such actions.

Always observe the information in these instructions when operating or repairing the system. The drive manufacturer does not accept liability for damage or injury resulting from improper usage.

## Assembling and disassembling the plug-in connecting cable



### Caution

The power supply to the connecting cable must be disconnected prior to assembly/disassembly.

### Assembling the plug-in connecting cable

Ø35/Ø45/Ø58

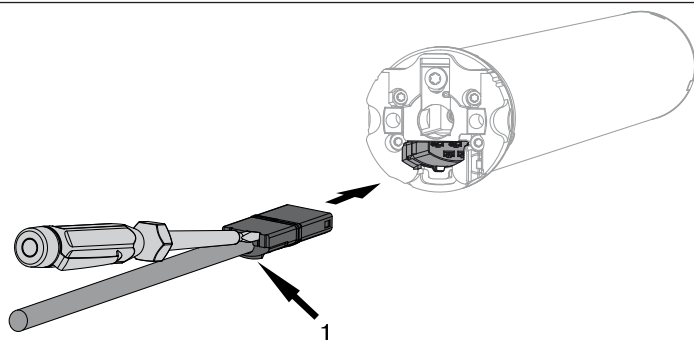

1 = locating lug

Insert the **dead** connecting cable into the drive head until the locating lug clicks into place in the drive. If necessary, use a suitable flathead screwdriver to assist with insertion. Set the screwdriver into one of the two plug grooves provided for this purpose.

Check that the cable is properly engaged.

### Disassembling the plug-in connecting cable for tubular drives

Ø35

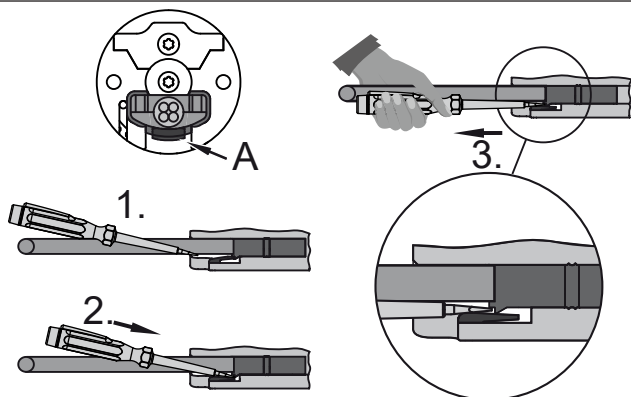

A = snap-in pin

Insert a suitable flathead screwdriver between the locating lug and the snap-in pin, so that the snap-in pin releases the locating lug from the plug.

Now you can pull out the connecting cable along with the flat-head screwdriver.

<b>Ø45/Ø58</b>	<p>Insert a suitable flathead screwdriver right into the recess of the locating latch, so that the latch releases the locating lug from the plug.</p> <p>Now you can pull out the connecting cable along with the flat-head screwdriver.</p>
A = locating latch	

## Assembly

### Assembling the drive

#### Attention

**To connect the drive to the driven part, solely mechanical accessory components made by the drive manufacturer from the current product catalogue may be used.**

Prior to mounting, the fitter must ensure that the masonry and the system being motorised are sufficiently robust (drive torque plus weight of the shading solution).



#### Caution

**Electrical connections may only be carried out by a qualified electrician. Prior to assembly, the power supply must be disconnected and secured. Please give the enclosed connection information to the responsible electrical contractor.**

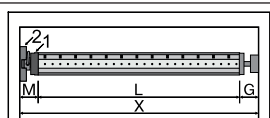

Calculate the space required at the side (M) by measuring the drive head (1) and wall bracket (2). The clear dimension of the box (X) minus the space required at the side (M) and idler (G) gives the length (L) of the barrel:  $L = X - M - G$ .

The space required at the side (M) varies depending on the combination of drive and wall bracket.

Then mount the wall bracket and idler. Ensure that the barrel is aligned at right angles to the wall and that sufficient axial play is allowed for the mounted system.

### Assembling and disassembling the mounting pin

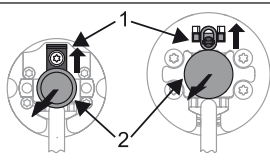

#### Ø45, Ø58

When pushed in, the mounting pin (2) locks automatically. To undo the mounting pin (2), push the tab washer (1) upwards and pull out the mounting pin (2).

### Assembling and disassembling the drive adapter

#### Fitting the ring onto the thrust ring

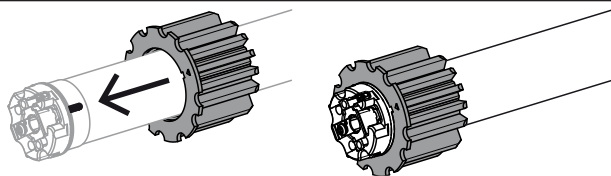

#### Assembling the drive adapter with safety catch on the drive shaft

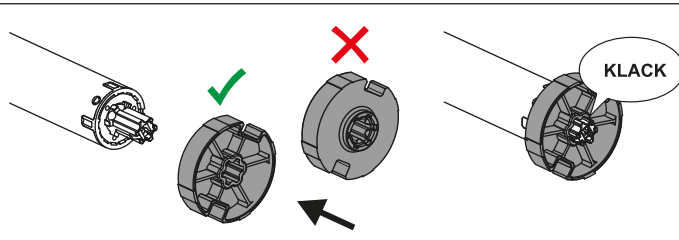

#### Disassembling the drive adapter with safety catch on the drive shaft

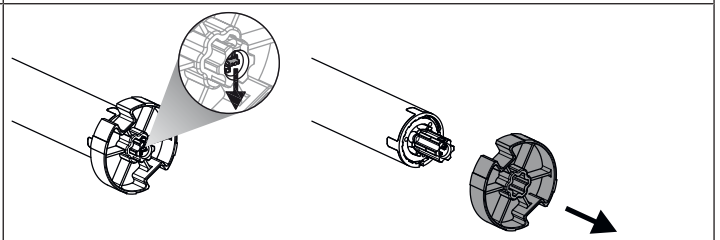

## Mounting the drive in the tube

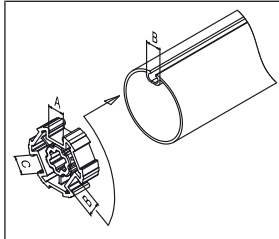

### For profile shafts:

In the case of some drive adapters, tolerances of the groove widths in different barrels can be offset by rotating the drive adapter into a different groove recess. These groove recesses have different sizes and allow the drive to fit exactly.



### For round shafts:

Measure the lug of the thrust ring (X, Y). Then notch the tube on the motor side, so the lug of the thrust ring can also be pushed into the shaft. There must be no play between the lug of the thrust ring and the shaft.

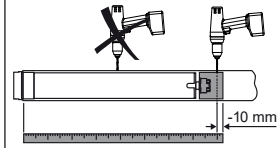

To ensure secure torque transmission for **round shafts**, we recommend screwing the drive adapter to the shaft (see the table below).

**Attention! When drilling into the barrel, never drill near the tubular drive!**

Size of drive [mm]	Drive adapter	Torque max. [Nm]	Fastening screws (4 units)
dia. 35-dia. 45	All	Up to 50	Self-tapping screw dia. 4.8 x 9.5 mm
dia. 58	Aluminium drive adapter	Up to 120	Countersunk screw M8 x 16 mm
dia. 58	Diecast drive adapter	Up to 120	Self-tapping screw dia. 6.3 x 13 mm

We also recommend screwing the idler to the barrel.

### Attention

**Do not hammer the tubular drive into the tube or drop it into the barrel!**

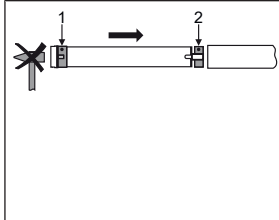

Assemble the tubular drive with the relevant ring (1) and drive adapter (2). If the ring has several grooves, select the groove which is a perfect fit and push the ring (1) onto the thrust ring.

Insert the tubular drive with the pre-assembled ring (1) and drive adapter (2) into the tube to achieve a form fit. Ensure that the ring and drive adapter are secure in the tube.

Mount the assembled unit comprising shaft, tubular drive and idler on the box and secure the drive with a splint or spring pin according to the type of wall bracket fixing.

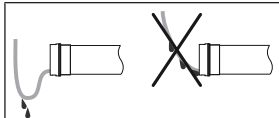

### Lay the connecting cable

Lay the connecting cable up to the tubular drive, and fix. The connecting cable must not project into the winding chamber. Cover any sharp edges.

The exterior antenna, if present, must not be shortened or damaged under any circumstances and also must not project into the winding space.

**⚠ Caution! Mains voltage may be present at a damaged or cut antenna. There is acute danger to life in the event of contact! Systems with a damaged antenna must be immediately disconnected and repaired.**

















## Compatible Centronic transmitters

All CentronicPlus receivers can be operated with the Centronic transmitters listed in the Centronic/CentronicPlus compatibility table at

[www.becker-antriebe.com/downloads](http://www.becker-antriebe.com/downloads)









As two fundamentally different radio technologies are linked in this case, the full performance of the CentronicPlus radio control system is not available in this combination. When using the Centronic transmitter with CentronicPlus receiver, the range performance may be reduced under certain circumstances. A Centronic transmitter cannot process feedback from the CentronicPlus receiver. The full performance of CentronicPlus is only achieved in combination with CentronicPlus transmitters, receivers and sensors, as only then will an intelligent, bidirectional system be automatically created.

## Explanation of functions

Explanation of symbols	
	Ascend / retract
	Descend / extend
	Ascend / retract disabled
	Descend / extend disabled
 or 	Centronic: The drive stops after releasing the respective travel button Centronic PLUS: The drive stops 5 s after pressing the respective travel button
	Wind
	Wind threshold value
	Sun
	Sun threshold value
	Rain
	No rain
	Sensor loss
	Intermediate position I
	Intermediate position II

## Awning operation

By pressing a travel button, the awning moves to the set limit position.

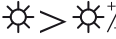
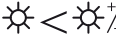
	Delay time	Response
<b>Behaviour in wind</b>		
		▲ ▼
	15 min.	Automatic
	60 min.	▲   ▼
<b>The receiver retracts when it rains</b>		
		▲
	15 min.	Automatic
<b>The receiver does not react to rain</b>		
		Automatic
		Automatic
<b>The receiver extends when it rains</b>		
		▼
	15 min.	Automatic
<b>Winter mode</b>		
		▲ ▼
<b>Automatic</b>		
	3 min.	▼*
	15 min.	▲

## Commissioning with a CentronicPLUS transmitter

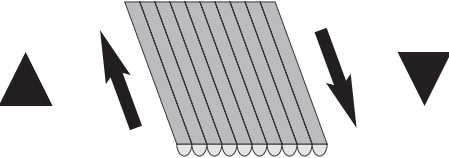
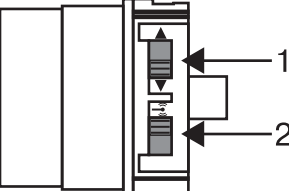

Explanation of symbols	
▲	Retract button
■	STOP button
▼	Extend button
●	Programming button (on the transmitter)
◻	Function button (on the transmitter)
	LED ring on the transmitter
	
(M) ...X	Receiver confirms once or multiple times by “clicking” or “shifting”
	1 = direction switch 2 = radio switch

### Attention

The tubular drives are designed for short-time operation. An inbuilt thermal protection switch prevents overheating of the tubular drive. During commissioning (long drop distance or long running time), the thermoswitch may trigger. The drive will switch off. After a short cooling-down period, the system is ready for operation again.

The drive does not achieve its full duty cycle until it has cooled to ambient temperature. Avoid a situation where the thermal protection switch cuts in repeatedly.

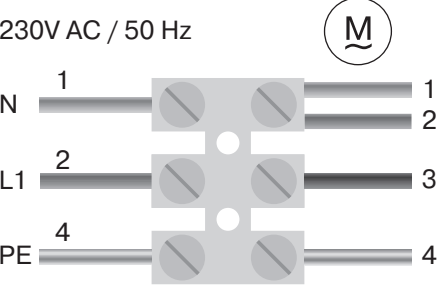

### Connecting the tubular drive

230V AC / 50 Hz	(M)	Connect the tubular drive to the power supply.
		
1 = blue	3 = black	
2 = brown	4 = green / yellow	
	(M) 1x	Switch on the power. ► The tubular drive confirms.

## Establish programming mode

**i** This step is only necessary if one of the devices to be programmed is not yet part of the installation. This is the case for brand new products, for example, or devices from another installation or products that have been restored to factory settings.

## Readying the tubular drive for programming by switching on the power

		<p>Switch on the power.</p> <ul style="list-style-type: none"> <li>▷ The tubular drive confirms.</li> <li>▶ The tubular drive is ready to program for 15 minutes.</li> </ul>
--	---	--

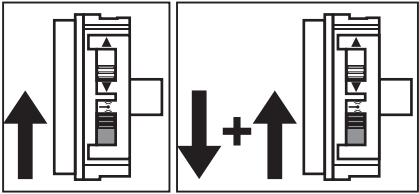

**i** If several tubular drives are to be connected in parallel, you can deactivate the programming mode on one tubular drive by switching the radio switch to the outside position after turning the power on.

## Readying the tubular drive for programming with the radio switch



	<p>Switch the radio switch to the inside position. If the radio switch is already in this position, switch it to the outside and back to the inside position.</p> <ul style="list-style-type: none"> <li>▶ The tubular drive is ready to program for 15 minutes.</li> </ul>
--	---







## Programming the CentronicPLUS transmitter

**i** With brand new products, devices from another installation or products that have been restored to factory settings, programming mode must be established beforehand (see Establishing programming mode).

	<p>Bring the transmitter as close as possible to the receiver to be programmed.</p>	
<p>● 3s</p>	 	<p>Press the programming button for 3 seconds when it is ready to program. The transmitter performs a search and the LED ring continuously changes colour. The transmitter then switches to receiver selection and selects the receiver with the best connection quality.</p> <ul style="list-style-type: none"> <li>▷ The receiver confirms.</li> </ul> <p>If you do not receive confirmation from the required receiver, you can press the ▲/▼ button to toggle between the available receivers until the required receiver confirms. Pressing the ▲ button for 3 seconds confirms the receiver with the best connection quality.</p> <ul style="list-style-type: none"> <li>▷ The transmitter displays the current assignment status of the receiver via the LED ring.</li> </ul>





### Assignment status

<p><b>Lights up yellow:</b></p>	<p>The receiver is not yet part of the installation or is in the <b>as-delivered condition</b>.</p>
<p><b>Lights up blue:</b></p>	<p>The receiver is <b>not assigned to the selected channel</b>.</p>
<p><b>Lights up green:</b></p>	<p>The receiver is <b>assigned to the selected channel</b>.</p>
<p><b>Lights up white:</b></p>	<p>Centronic PLUS sensor selected.</p>
<p><b>Lights up purple</b></p>	<p>Centronic PLUS transmitter selected.</p>
<p><b>Lights up red:</b></p>	<p>No receiver located.</p>
	 <p>Select the desired channel by pressing the function key on the multi-channel handheld transmitter.</p>





	 or  	<p>Press the STOP button to change the assignment status of the selected receiver. If the receiver is not yet part of the installation, it will be added and assigned to the selected channel.</p> <ul style="list-style-type: none"> <li>▶ The receiver signals once to confirm the channel assignment, or signals twice to cancel the channel assignment.</li> <li>▶ The transmitter lights up accordingly to confirm the new assignment status.</li> <li>▶ The receiver is now part of the installation with the required channel assignment.</li> </ul>
		<p>Then press the programming button for 3 seconds to change to normal mode.</p> <ul style="list-style-type: none"> <li>▶ The LED ring goes out.</li> </ul>

### Adding additional transmitters to the installation

**i** If installation data already exists for the transmitter being programmed, the procedure will be terminated. Termination is indicated by the red flashing of the LED ring. In this case, the transmitter will need to be restored to factory settings (see corresponding transmitter instructions).

	 	<p>Press the programming button on an already programmed transmitter for 3 seconds. The transmitter performs a search and the LED ring continuously changes colour. The transmitter then switches to receiver selection and selects the receiver with the best connection quality.</p> <ul style="list-style-type: none"> <li>▶ The receiver confirms.</li> </ul>
		<p>Now press and hold the programming button for a new transmitter.</p> <ul style="list-style-type: none"> <li>▶ After 5 seconds, the LED rings on both transmitters start to fill in green.</li> </ul> <p>Continue pressing and holding the programming button.</p> <ul style="list-style-type: none"> <li>▶ Once the new transmitter has been added successfully, both transmitters flash green to confirm.</li> <li>▶ The transmitter has been added successfully.</li> </ul> <p><b>i</b> The programming process can be terminated at any time by pressing the STOP button on the transmitter that has already been programmed or by releasing the programming button.</p>

### Selection of the receiver for the setting mode

		<p>Bring the transmitter as close as possible to the required receiver.</p>
	 	<p>Press the programming button for 3 seconds. The transmitter performs a search and the LED ring continuously changes colour. The transmitter then switches to receiver selection and selects the receiver with the best connection quality.</p> <ul style="list-style-type: none"> <li>▶ The receiver confirms.</li> </ul> <p>If you do not receive confirmation from the required receiver, you can press the ▲/▼ button to toggle between the available receivers until the required receiver confirms. Pressing the ▲ button for 3 seconds confirms the receiver with the best connection quality.</p> <ul style="list-style-type: none"> <li>▶ The transmitter displays the current assignment status of the receiver via the LED ring.</li> </ul>

#### Assignment status

<b>Lights up yellow:</b>	The receiver is not yet part of the installation or is in the <b>as-delivered condition</b> .
<b>Lights up blue:</b>	The receiver is <b>not assigned to the selected channel</b> .
<b>Lights up green:</b>	The receiver is <b>assigned to the selected channel</b> .
<b>Lights up white:</b>	Centronic PLUS sensor selected.
<b>Lights up purple</b>	Centronic PLUS transmitter selected.

<b>Lights up red:</b>		No receiver located.
●	(M) 1x	Briefly press the programming button to change to the setting mode. <ul style="list-style-type: none"> <li>▷ The receiver confirms.</li> <li>▷ The LED ring of the transmitter slowly pulses light blue.</li> <li>▷ The receiver now enters dead-man mode.</li> </ul> <ul style="list-style-type: none"> <li>▶ The setting mode is now active.</li> </ul> <p><b>i</b> If a receiver has not yet been added to the installation (LED ring lights up yellow), it will not be possible to select it in this way. The receiver must be added to the installation beforehand. See chapter “Programming CentronicPLUS transmitters”.</p>
		

### Checking that the running direction is correct

**i** The direction of rotation can only be changed if no limit position has been set.

There are several ways to change the direction of rotation:

- Changing direction of rotation via the direction switch
- Changing direction of rotation via the transmitter

### Changing direction of rotation via the direction switch

Press the ▲ or ▼ button.

- ▷ The shading solution runs in the desired direction
- ▶ The running direction is OK.

If the shading solution runs in the wrong direction, the running direction must be changed. Proceed as follows:

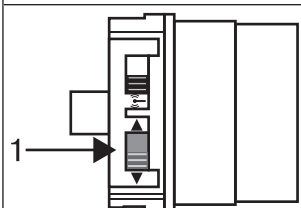
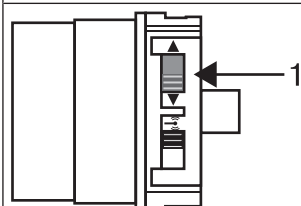

Switch the direction switch (1) to the opposite position.

- ▷ The running direction will now have changed.
- ▶ Check the running direction again.

### Changing the direction of rotation with a CentronicPLUS transmitter



Select the required receiver as described in the chapter Selection of the receiver for the setting mode [▶ 13].

Press the ▲ or ▼ button.

- ▷ The shading solution runs in the desired direction.
- ▶ The running direction is OK. Now change back to normal mode, as described in the previous step.

If the shading solution runs in the wrong direction, the running direction must be changed. Proceed as follows:

●+▲+▼  
3s

(M) 3x



First, press the programming button, then within 3 seconds also press the ▲ and ▼ button for 3 seconds.

- ▷ The receiver confirms.
- ▷ The transmitter confirms with a red/blue rotation of the LED ring.

Check the running direction again.

● 3s		Then press the programming button for 3 seconds to change to normal mode. ▶ The LED ring goes out.
------	--	---

## Intelligent installation management

### Completion of installation following automatic setting of limit positions

The drive saves the limit position permanently once the upper limit position is reached 3 times in succession. Installation is then complete. If the limit position is set above a point, this is stored permanently.

### Limit position status indicator

A brief stopping and restarting indicates that no limit position has been set in that direction of movement.

### Setting the limit positions

**i** The running direction must be correct. When setting the limit positions, the tubular drive runs in dead-man mode and limit position status indicator. The extended limit position must always be set first. If the tubular drive switches off prematurely while extending/retracting, due to an obstruction, the obstruction can be cleared by extending/retracting the screen and removing the obstruction. The upper limit position can be set by extending/retracting again.





### There are several ways to set the limit positions:

- Extended point to retracted point
- Extended point to retracted stop
- Auto install



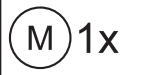



The limit position becomes fixed after the tubular drive has turned off **automatically** in the desired position three times.

#### Extended point to retracted point

**i** There is no shading solution length adjustment with this limit position setting.

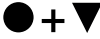
		Select the required receiver as described in the chapter Selection of the receiver for the setting mode [▶ 13].
▼		Open to the desired extended limit position.
● + ▼	 	Press the programming button and, within 3 seconds, also press the extend button and hold the two buttons down. ▶ The tubular drive confirms. ▶ The transmitter confirms by lighting up the upper third of the LED ring.
▲		Then close to the desired retracted limit position.
● + ▲	 	Press the programming button and, within 3 seconds, also press the retract button and hold the two buttons down. ▶ The tubular drive confirms. ▶ The transmitter confirms by lighting up the lower third of the LED ring green. ▶ The limit positions are now set.
● 3s		Then press the programming button for 3 seconds to change to normal mode. ▶ The LED ring goes out.





## Extended point to retracted stop

	Select the required receiver as described in the chapter Selection of the receiver for the setting mode [▶ 13].
	Open to the desired extended limit position.
 	Press the programming button and, within 3 seconds, also press the extend button and hold the two buttons down. <ul style="list-style-type: none"> <li>▶ The tubular drive confirms.</li> <li>▶ The transmitter confirms by lighting up the lower third of the LED ring green.</li> </ul>
	
	Then retract to the permanent stop. <ul style="list-style-type: none"> <li>▶ The tubular drive switches off automatically.</li> <li>▶ The limit positions are now set.</li> </ul>
	Then press the programming button for 3 seconds to change to normal mode. The LED ring goes out.

## Changing the additional stop behaviour function

On delivery, the 35 diameter drive types have a reduced stop behaviour, and the 45 diameter and 58 diameter drive types have an increased stop behaviour.

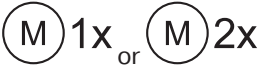



Proceed as follows to change the stop behaviour:

<b>i The "to retracted stop" limit position must be set in order to adjust the stop behaviour. The stop behaviour can be changed during the first 3 runs towards the stop.</b>	
	Select the required receiver as described in the chapter Selection of the receiver for the setting mode [▶ 13].
	Press and hold the retract button in order to retract the sun protection system.
	While retracting, <b>also</b> press the programming button until the tubular drive switches off automatically at the stop, and continue holding the two buttons down until confirmation is complete.
	The tubular drive confirms. 1 shift = reduced stop behaviour 2 shifts = increased stop behaviour
	The transmitter confirms by lighting up the upper third of the LED ring.
	Then press the programming button for 3 seconds to change to normal mode. <ul style="list-style-type: none"> <li>▶ The LED ring goes out.</li> </ul>



## Changing the set limit positions







### 1) Shortening the range of travel (the desired limit position is located inside the current range of travel)

		Select the required receiver as described in the chapter Selection of the receiver for the setting mode [▶ 13].
▲ / ▼		Open/close to the desired new limit position.
● + ▲ or ● + ▼	 	<p>First press and hold the programming button, then within 3 seconds also press and hold the ▼ button for the extend limit position, or the ▲ button for the retract limit position. Hold the two buttons down.</p> <ul style="list-style-type: none"> <li>▶ The tubular drive confirms.</li> <li>▶ The transmitter confirms by lighting up the upper/lower third of the LED ring.</li> <li>▶ The new limit position is now saved.</li> </ul>
● 3s		<p>Then press the programming button for 3 seconds to change to normal mode.</p> <ul style="list-style-type: none"> <li>▶ The LED ring goes out.</li> </ul>

### 2) Extending the range of travel (the desired limit position is located outside the current range of travel)

#### Attention

**When both or individual limit positions are deleted, all the other set functions (intermediate position I, intermediate position II) are deleted as well.**

		Select the required receiver as described in the chapter Selection of the receiver for the setting mode [▶ 13].
▲ / ▼		Open/close to the limit position in the direction in which you wish to extend the range of travel.
● + ■ 3s	 	<p>Press the programming button and, within the next 3 seconds, press the STOP button at the same time and hold the two buttons down for 3 seconds.</p> <ul style="list-style-type: none"> <li>▶ The tubular drive confirms.</li> <li>▶ The transmitter confirms with red pulsing of the LED ring.</li> <li>▶ The limit position is now deleted.</li> </ul>
▲ / ▼		Open/close to the desired new limit position.
● + ▲ or ● + ▼	 	<p>First press and hold the programming button, then within 3 seconds also press and hold the ▼ button for the extend limit position, or the ▲ button for the retract limit position. Hold the two buttons down.</p> <ul style="list-style-type: none"> <li>▶ The tubular drive confirms.</li> <li>▶ The transmitter confirms by lighting up the upper/lower third of the LED ring.</li> <li>▶ The new limit position is now saved.</li> </ul>
● 3s		<p>Then press the programming button for 3 seconds to change to normal mode.</p> <ul style="list-style-type: none"> <li>▶ The LED ring goes out.</li> </ul>

## Setting the limit positions with Auto-Install

### Intelligent installation management

#### Completion of installation following automatic setting of limit position "Stop"

Next time the "stop" limit position is travelled to, this position will be provisionally saved as the limit position. Once the limit position has been detected at this position 3 times in a row without any problems, it will be definitively saved. This normally takes place during regular operation.

To complete installation quickly, it is sufficient to travel to the "stop" limit position 3 times in a row from approx. 20 cm.

#### Limit position status indicator

A brief stopping and restarting indicates that no limit position has been set in that direction of movement.

### Setting the limit positions

There are several ways to set the limit positions:

- Start point to retracted stop
- Auto point to retracted stop (only with articulated-arm awnings)



**These tubular drives are designed for short-time operation (for the operating mode, please see technical data).**

**The number of cycles an awning is capable of depends on the barrel diameter and awning extension.**

**The drive running time is cut short if the drive has not cooled down fully after the previous use.**

### Start point to retracted stop

	Move the sun protection system to the desired maximum projection. This must be at least 2.5 revolutions of the barrel away from the retracted limit position. At this time, it is still possible to amend the position.
	Then, retract the sun protection system <b>without interruption</b> until the tubular drive switches off automatically. <ul style="list-style-type: none"><li>► Installation is now complete; electronic limit switching has saved the limit positions. As a final check, run the system to the two limit positions again.</li></ul> To ensure that the limit position is reliably detected and the sun protection system is fully closed, the tubular drive pulls the cloth slightly more strongly during the installation.

## Auto point to retracted stop (only with articulated-arm awnings)

### Attention

Ensure that the cloth is not wound up the wrong way by the barrel.

	Select the required receiver as described in the chapter Selection of the receiver for the setting mode [▶ 13].
▼	Extend the articulated-arm awning until the articulated arms are fully protracted and the cloth is lying loosely over them.
▲	Then, retract the articulated-arm awning <b>without interruption</b> until the tubular drive switches off automatically. <ul style="list-style-type: none"> <li>▶ Installation is now complete; electronic limit switching has saved the limit positions. As a final check, run the system to the two limit positions again.</li> </ul> <p>To ensure that the limit position is reliably detected and the sun protection system is fully closed, the tubular drive pulls the cloth slightly more strongly during the installation.</p>
● 3s	
	Then press the programming button for 3 seconds to change to normal mode. The LED ring goes out.

## Deleting the limit positions

### Attention







When both or individual limit positions are deleted, all the other set functions (intermediate position I, intermediate position II) are deleted as well.

## Deleting individual limit positions

		Select the required receiver as described in the chapter Selection of the receiver for the setting mode [▶ 13].
▲ / ▼		Open/close to the limit position to be deleted.
● + ■ 3s	 	Press the programming button and, within the next 3 seconds, press the STOP button at the same time and hold the two buttons down for 3 seconds. <ul style="list-style-type: none"> <li>▶ The tubular drive confirms.</li> <li>▶ The transmitter confirms with red pulsing of the LED ring.</li> <li>▶ The limit position is now deleted.</li> </ul>
● 3s		Then press the programming button for 3 seconds to change to normal mode. <ul style="list-style-type: none"> <li>▶ The LED ring goes out.</li> </ul>

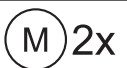
## Deleting both limit positions





**i** Any additional functions that may have been set are deleted at the same time, or are reset to the factory default settings.

		Select the required receiver as described in the chapter Selection of the receiver for the setting mode [▶ 13].
		Open/close the shading solution to a point between the limit positions.
 3s	 	Press the programming button and, within the next 3 seconds, press the STOP button at the same time and hold the two buttons down for 3 seconds. <ul style="list-style-type: none"> <li>▶ The tubular drive confirms.</li> <li>▶ The transmitter confirms with red pulsing of the LED ring.</li> <li>▶ The limit positions are now deleted.</li> </ul>
 3s		Then press the programming button for 3 seconds to change to normal mode. <ul style="list-style-type: none"> <li>▶ The LED ring goes out.</li> </ul>

## Intermediate positions I + II

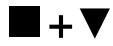
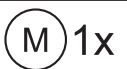

**i** The intermediate positions I + II are freely selectable positions for the shading solution between the two limit positions. Each travel button can be assigned one intermediate position. Both limit positions must be set before an intermediate position is set.

### Setting/modifying the desired intermediate position



		Open/close the shading solution to the desired intermediate position.
 or 	 	Press the STOP button and, within 3 seconds, also press the desired travel button and hold the two buttons down. <ul style="list-style-type: none"> <li>▶ The receiver confirms.</li> <li>▶ The transmitter confirms by lighting up the upper/lower third of the LED ring light blue.</li> <li>▶ The intermediate position is now saved.</li> </ul>

**i** If several receivers are operated on the same channel, a specific receiver can also be selected beforehand. You can select the required receiver beforehand by following the description in the chapter Selection of the receiver for the setting mode [▶ 13].

### Travelling to the desired intermediate position

 or 		Press the travel button for the desired intermediate position twice within one second. <ul style="list-style-type: none"> <li>▶ The transmitter confirms with a rotational movement of the LED ring from blue to turquoise.</li> <li>▶ The shading solution travels to the intermediate position assigned to the travel button.</li> </ul>
--	---	--

## Deleting the desired intermediate position

<p>2x ▲ or 2x ▼</p>		<p>Move the shading solution to the intermediate position that is to be deleted.</p>
<p>■ + ▲ or ■ + ▼</p>	<p>(M) 2x</p> 	<p>Now press the STOP button and, within 3 seconds, also press the travel button assigned to the intermediate position and hold the two buttons down.</p> <ul style="list-style-type: none"> <li>▷ The receiver confirms.</li> <li>▷ The transmitter confirms by lighting up the upper/lower third of the LED ring light blue.</li> <li>▶ The intermediate position is now deleted.</li> </ul>

## Deleting the intermediate positions

<p>■ + ■ 5s</p>	<p>(M) 2x</p> 	<p>Press the STOP button twice within 1 second and then press and hold for 5 seconds.</p> <ul style="list-style-type: none"> <li>▷ The receiver confirms.</li> <li>▷ The transmitter confirms with red pulsing of the LED ring.</li> <li>▶ The intermediate positions have now been deleted.</li> </ul>
-----------------	---	---



## Restoring the wireless memory of the tubular drive to factory settings

There are a number of options:

- Using a programmed CentronicPlus transmitter
- Using the universal programming unit (item no. 4935 000 001 0)





**i** The set limit positions and all of the other set functions (intermediate position I, intermediate position II, fabric untensioning, fabric stretching, stop behaviour, obstruction detection) are retained.

## Using a programmed CentronicPlus transmitter





		<p>Bring the transmitter as close as possible to the required receiver.</p>
<p>● 3s</p>	<p>(M) 1x</p> 	<p>Press the programming button for 3 seconds. The transmitter performs a search and the LED ring continuously changes colour. The transmitter then switches to receiver selection and selects the receiver with the best connection quality.</p> <ul style="list-style-type: none"> <li>▷ The receiver confirms.</li> </ul> <p>If you do not receive confirmation from the required receiver, you can press the ▲/▼ button to toggle between the available receivers until the required receiver confirms. Pressing the ▲ button for 3 seconds confirms the receiver with the best connection quality.</p> <ul style="list-style-type: none"> <li>▷ The transmitter displays the current assignment status of the receiver via the LED ring.</li> </ul>

### Assignment status

<p><b>Lights up yellow:</b></p>	<p>The receiver is not yet part of the installation or is in the <b>as-delivered condition</b>.</p>
<p><b>Lights up blue:</b></p>	<p>The receiver is <b>not assigned to the selected channel</b>.</p>
<p><b>Lights up green:</b></p>	<p>The receiver is <b>assigned to the selected channel</b>.</p>
<p><b>Lights up white:</b></p>	<p>Centronic PLUS sensor selected.</p>
<p><b>Lights up purple</b></p>	<p>Centronic PLUS transmitter selected.</p>
<p><b>Lights up red:</b></p>	<p>No receiver located.</p>

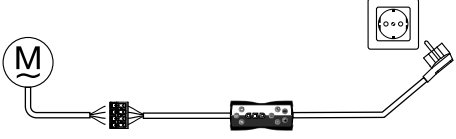
●	 1x 	<p>Briefly press the programming button to change to the setting mode.</p> <ul style="list-style-type: none"> <li>▷ The receiver confirms.</li> <li>▷ The LED ring of the transmitter slowly pulses light blue.</li> <li>▷ The receiver now enters dead-man mode.</li> <li>▷ The setting mode is now active.</li> </ul>
● + ▲ + ■ + ▼ 3s	 2x 	<p>Then press the programming button and also the ▲ button, the STOP button and the ▼ button for approximately 3 seconds.</p> <ul style="list-style-type: none"> <li>▷ The receiver confirms.</li> <li>▷ The transmitter confirms with a red rotation of the LED ring.</li> <li>▶ The wireless memory of the tubular drive is now restored to factory settings.</li> </ul>

### Using the universal programming unit (item no. 4935 000 001 0)

	<p>Connect the wires of the tubular drive to those of the same colour in the programming unit.</p>
	<p>Connect the programming unit to the mains supply.</p>
	<p>Now press and hold the button "Tubular drive with electronic limit switching and radio".</p>
 10s	 2x <p>Then press the "Delete transmitter" button for 10 seconds.</p> <ul style="list-style-type: none"> <li>▷ The tubular drive confirms.</li> <li>▶ The tubular drive has now deleted all wireless assignments.</li> </ul>

## Commissioning with a Centronic transmitter

Explanation of symbols	
▲	Retract button
■	STOP button
▼	Extend button
●	Programming button (on the transmitter)
(M) ...X	Receiver confirms once or multiple times by “clicking” or “shifting”
	1 = direction switch 2 = radio switch

### Attention

The tubular drives are designed for short-time operation. An inbuilt thermal protection switch prevents overheating of the tubular drive. During commissioning (long drop distance or long running time), the thermoswitch may trigger. The drive will switch off. After a short cooling-down period, the system is ready for operation again. The drive does not achieve its full duty cycle until it has cooled to ambient temperature. Avoid a situation where the thermal protection switch cuts in repeatedly.

### Connecting the tubular drive

230V AC / 50 Hz 	(M)	Connect the tubular drive to the power supply.
1 = blue	3 = black	
2 = brown	4 = green / yellow	
	(M) 1x	Switch on the power. ► The tubular drive confirms.

### Readying the tubular drive for programming by switching on the power

	(M) 1x	Switch on the power. ► The tubular drive confirms. ► The tubular drive is ready to program for 3 minutes.
--	--------	---

**i** If several tubular drives are to be connected in parallel, you can deactivate the programming mode on one tubular drive by switching the radio switch to the outside position after turning the power on.

### Readying the tubular drive for programming with the radio switch

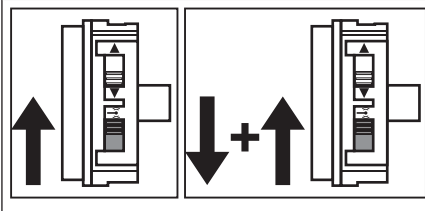

Switch the radio switch to the inside position. If the radio switch is already in this position, switch it to the outside and back to the inside position.

- The tubular drive is ready to program for 3 minutes.

### Intelligent installation management

#### Completion of installation following automatic setting of limit positions

The drive saves the limit position permanently once the upper limit position is reached 3 times in succession. Installation is then complete. If the limit position is set above a point, this is stored permanently.

#### Limit position status indicator

A brief stopping and restarting indicates that no limit position has been set in that direction of movement.

### Programming the master transmitter



Press the programming button for 3 seconds when it is ready to programme.

- The tubular drive acknowledges.
- The programming process is now complete.

**i** If a transmitter is already programmed on the receiver, press the programming button for 10 seconds.

### Checking that the running direction is correct

**i** The direction of rotation can only be changed if no limit position has been set.

There are several ways to change the direction of rotation:

- Changing direction of rotation via the direction switch
- Changing direction of rotation via master transmitter

### Changing direction of rotation via the direction switch

Press the ▲ or ▼ button.

- The shading solution runs in the desired direction
- The running direction is OK.

If the shading solution runs in the wrong direction, the running direction must be changed. Proceed as follows:

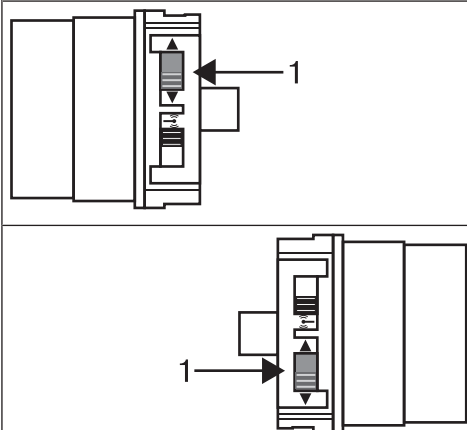

Switch the direction switch (1) to the opposite position.

- The running direction will now have changed.
- Check the running direction again.



## Changing direction of rotation via master transmitter

Press the ▲ or ▼ button.

▷ The shading solution runs in the desired direction.

▶ The running direction is OK.

If the shading solution runs in the wrong direction, the running direction must be changed. Proceed as follows:

<p>●+▲+▼ 3s</p>	<p>(M) 3x</p>	<p>First, press the programming button, then within 3 seconds also press the ▲ and ▼ button for 3 seconds.</p> <p>▶ The tubular drive confirms.</p> <p>Check the running direction again.</p>
---------------------	---------------	---

## Setting the limit positions

**i** The limit positions can only be set with the master transmitter. The shutter direction must be correct. When setting the limit positions, the tubular drive runs in dead-man mode and limit position status indicator. The extended limit position must always be set first. If the tubular drive switches off prematurely while extending/retracting, due to an obstruction, the obstruction can be cleared by extending/retracting the screen and removing the obstruction. The upper limit position can be set by extending/retracting again.

### There are several ways to set the limit positions:

- Extended point to retracted point
- Extended position to retracted stop
- Auto install

The limit position becomes fixed after the tubular drive has turned off **automatically** in the desired position three times.

#### Extended point to retracted point

**i** There is no shading solution length adjustment with this limit position setting.

▼		Open to the desired extended limit position.
●+▼	(M) 1x	<p>Press the programming button and, within 3 seconds, also press the extend button and hold the two buttons down.</p> <p>▷ The tubular drive acknowledges.</p>
▲		Then close to the desired retracted limit position.
●+▲	(M) 1x	<p>Press the programming button and, within 3 seconds, also press the retract button and hold the two buttons down.</p> <p>▷ The tubular drive acknowledges.</p> <p>▶ The limit positions are now set.</p>

#### Extended point to retracted stop

▼		Open to the desired extended limit position.
●+▼	(M) 1x	<p>Press the programming button and, within 3 seconds, also press the extend button and hold the two buttons down.</p> <p>▷ The tubular drive acknowledges.</p>
▲		<p>Then retract to the permanent stop.</p> <p>▷ The tubular drive switches off automatically.</p> <p>▶ The limit positions are now set.</p>

## Changing the additional stop behaviour function with the master transmitter

On delivery, the 35 diameter drive types have a reduced stop behaviour, and the 45 diameter and 58 diameter drive types have an increased stop behaviour.

Proceed as follows to change the stop behaviour:

**i** The "to retracted stop" limit position must be set in order to adjust the stop behaviour. The stop behaviour can be changed during the first 3 runs towards the stop.

▲	Press and hold the retract button in order to retract the sun protection system.
▲ + ●	While retracting, <b>also</b> press the programming button until the tubular drive switches off automatically at the stop, and continue holding the two buttons down until confirmation is complete.
(M) 1x or (M) 2x	The tubular drive confirms. 1 shift = reduced stop behaviour 2 shifts = increased stop behaviour

## Changing the set limit positions

**i** Once set, the limit positions can only be changed with the master transmitter.

### 1) Shortening the range of travel (the desired limit position is located inside the current range of travel)

▲ / ▼	Open/close to the desired new limit position.
● + ▲ or ● + ▼	(M) 1x First press and hold the programming button, then within 3 seconds also press and hold the ▼ button for the extend limit position, or the ▲ button for the retract limit position. Hold the two buttons down. <ul style="list-style-type: none"> <li>▷ The tubular drive confirms.</li> <li>▶ The new limit position is now saved.</li> </ul>

### 2) Extending the range of travel (the desired limit position is located outside the current range of travel)

#### Attention

When both or individual limit positions are deleted, all the other set functions (intermediate position I, intermediate position II) are deleted as well.

▲ / ▼	Open/close to the limit position in the direction in which you wish to extend the range of travel.
● + ■	(M) 2x Press the programming button and, within the next 3 seconds, press the STOP button at the same time and hold the two buttons down for 10 seconds. <ul style="list-style-type: none"> <li>▷ The tubular drive confirms.</li> <li>▶ The limit position is now deleted.</li> </ul>
▲ / ▼	Open/close to the desired new limit position.
● + ▲ or ● + ▼	(M) 1x First press and hold the programming button, then within 3 seconds also press and hold the ▼ button for the extend limit position, or the ▲ button for the retract limit position. Hold the two buttons down. <ul style="list-style-type: none"> <li>▷ The tubular drive confirms.</li> <li>▶ The new limit position is now saved.</li> </ul>

## Setting the limit positions with Auto-Install

### Intelligent installation management

#### Completion of installation following automatic setting of limit position "Stop"

Next time the "stop" limit position is travelled to, this position will be provisionally saved as the limit position. Once the limit position has been detected at this position 3 times in a row without any problems, it will be definitively saved. This normally takes place during regular operation.

To complete installation quickly, it is sufficient to travel to the "stop" limit position 3 times in a row from approx. 20 cm.

#### Limit position status indicator

A brief stopping and restarting indicates that no limit position has been set in that direction of movement.

### Setting the limit positions

There are several ways to set the limit positions:

- Start point to retracted stop
- Auto point to retracted stop (only with articulated-arm awnings)



**These tubular drives are designed for short-time operation (for the operating mode, please see technical data).**

**The number of cycles an awning is capable of depends on the barrel diameter and awning extension.**

**The drive running time is cut short if the drive has not cooled down fully after the previous use.**

### Start point to retracted stop

▼	<p>Move the sun protection system to the desired maximum projection. This must be at least 2.5 revolutions of the barrel away from the retracted limit position. At this time, it is still possible to amend the position.</p>
▲	<p>Then, retract the sun protection system <b>without interruption</b> until the tubular drive switches off automatically.</p> <p>Installation is now complete; electronic limit switching has saved the limit positions. As a final check, run the sun protection system to the two limit positions again.</p> <p>To ensure that the limit position is reliably detected and the sun protection system is fully closed, the tubular drive pulls the cloth slightly more strongly during the installation.</p>

## Auto point to retracted stop (only with articulated-arm awnings)

### Attention

Ensure that the cloth is not wound up the wrong way by the barrel.

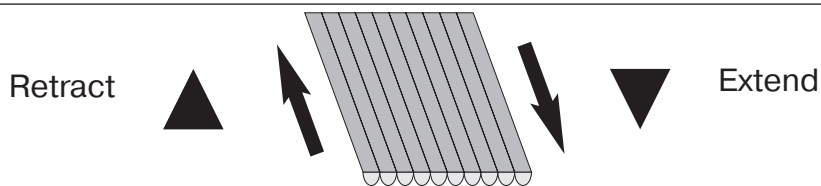

▼	Extend the articulated-arm awning until the articulated arms are fully protracted and the cloth is lying loosely over them.
▲	Then, retract the articulated-arm awning <b>without interruption</b> until the tubular drive switches off automatically.  Installation is now complete; electronic limit switching has saved the limit positions. As a final check, run the sun protection system to the two limit positions again.  To ensure that the limit position is reliably detected and the sun protection system is fully closed, the tubular drive pulls the cloth slightly more strongly during the installation.

## Deleting the limit positions

### Attention

When both or individual limit positions are deleted, all the other set functions (intermediate position I, intermediate position II) are deleted as well.



Once set, the limit positions can only be deleted with the master transmitter.

## Deleting individual limit positions

▲ / ▼		Open/close to the limit position to be deleted.
● + ■ 10s	(M) 2x	Press the programming button and, within 3 seconds, also press the STOP button and hold the two buttons down for 10 seconds.  ▷ The tubular drive acknowledges.  ▶ The limit position is now deleted.

## Deleting both limit positions



Any additional functions that may have been set are deleted at the same time, or are reset to the factory default settings.

▲ / ▼		Open/close the shading solution to a point between the limit positions.
● + ■ 10s	(M) 2x	Press the programming button and, within the next 3 seconds, press the STOP button at the same time and hold the two buttons down for 10 seconds.  ▷ The tubular drive acknowledges.  ▶ The limit positions are now deleted.

## Intermediate positions I + II

**i** The intermediate positions I + II are freely selectable positions for the shading solution between the two limit positions. Each travel button can be assigned one intermediate position. Both limit positions must be set before an intermediate position is set.

### Setting/modifying the desired intermediate position

▲ / ▼		Open/close the shading solution to the desired intermediate position.
■ + ▲ or ■ + ▼	(M) 1x	Press the STOP button and, within 3 seconds, also press the desired travel button and hold the two buttons down. <ul style="list-style-type: none"> <li>▷ The tubular drive confirms.</li> <li>▶ The intermediate position is now saved.</li> </ul>

### Travelling to the desired intermediate position

2x ▲ or 2x ▼		Press the travel button for the desired intermediate position twice within one second. <ul style="list-style-type: none"> <li>▶ The curtain runs to the intermediate position assigned to the travel button.</li> </ul>
--------------------	--	---

### Deleting the desired intermediate position

2x ▲ or 2x ▼		Move the shading solution to the intermediate position that is to be deleted.
■ + ▲ or ■ + ▼	(M) 2x	Now press the STOP button and, within 3 seconds, also press the travel button assigned to the intermediate position and hold the two buttons down. <ul style="list-style-type: none"> <li>▷ The tubular drive confirms.</li> <li>▶ The intermediate position is now deleted.</li> </ul>

### Programming additional transmitters

**i** In addition to the master transmitter, up to 15 further transmitters can be programmed in the tubular drive. Before programming a radio controlled Sun-Wind-Sensor, the limit positions must be programmed.

● 3s	(M) 1x	Press the programming button of the master transmitter for 3 seconds. <ul style="list-style-type: none"> <li>▷ The tubular drive acknowledges.</li> </ul>
● 3s	(M) 1x	Now press the programming button of a new transmitter which has not yet been programmed in the tubular drive for 3 seconds. Doing so activates the programming mode of the tubular drive for a new transmitter for 3 minutes. <ul style="list-style-type: none"> <li>▷ The tubular drive acknowledges.</li> </ul>
● 3s	(M) 2x	Now press the programming button of the new transmitter you wish to program again for 3 seconds. <ul style="list-style-type: none"> <li>▷ The tubular drive acknowledges.</li> <li>▶ The new transmitter has now been programmed.</li> </ul>

## Deleting transmitters

### Deleting individual transmitters

**i** The programmed master transmitter cannot be deleted. It can only be overwritten (see Programming the master transmitter [▶ 24]).

● 3s	(M) 1x	Press the programming button on the master transmitter for 3 seconds. ▶ The tubular drive acknowledges.
● 3s	(M) 1x	Now press the programming button of the transmitter to be deleted for 3 seconds. ▶ The tubular drive acknowledges.
● 10s	(M) 2x	Then press the programming button of the transmitter to be deleted again for 10 seconds. ▶ The tubular drive acknowledges. ▶ The transmitter is now deleted from the tubular drive.

### Deleting all transmitters (except the master transmitter)

● 3s	(M) 1x	Press the programming button on the master transmitter for 3 seconds. ▶ The tubular drive acknowledges.
● 3s	(M) 1x	Re-press the programming button on the master transmitter for 3 seconds. ▶ The tubular drive acknowledges.
● 10s	(M) 2x	Re-press the programming button on the master transmitter for 10 seconds. ▶ The tubular drive acknowledges. ▶ All transmitters (except the master transmitter) are now deleted from the receiver.



### Overwriting the master

There are two ways to overwrite the master:

- Ready the tubular drive for programming by switching on the power
- Ready the tubular drive for programming with the radio switch

### Readying the tubular drive for programming by switching on the power

**i** To ensure that the new master transmitter is programmed in the desired tubular drive only, all other tubular drives which are connected to the same power supply must be deactivated from the programming mode. To do so, after switching back on the power, execute a drive or stop command using the transmitter for the given tubular drives or switch the radio switch from inside to outside. If the radio switch is already in this position, switch it to the inside and back to the outside position.

		Switch off the power supply to the tubular drive.
	(M) 1x	Switch the power supply to the tubular drive back on after 5 seconds. ▶ The tubular drive confirms. ▶ The tubular drive is ready to program for 3 minutes.
● 10s	(M) 2x	Now press the programming button of the new master transmitter for 10 seconds. ▶ The tubular drive confirms. ▶ The new master transmitter has now been programmed and the old master transmitter overwritten.

## Readying the tubular drive for programming with the radio switch

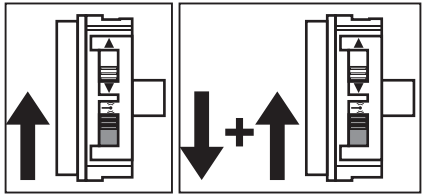
	<p>Switch the radio switch to the inside position. If the radio switch is already in this position, switch it to the outside and back to the inside position.</p> <ul style="list-style-type: none"> <li>▷ The tubular drive is ready to program for 3 minutes.</li> </ul>
<p>● 10s</p>	<p>(M) 2x</p> <p>Now press the programming button of the new master transmitter for 10 seconds.</p> <ul style="list-style-type: none"> <li>▷ The tubular drive confirms.</li> <li>▶ The new master transmitter has now been programmed and the old master transmitter overwritten.</li> </ul>



## Additional functions with CentronicPLUS / Centronic

### Activating/deactivating the additional fabric tensioning function

**i** The "to retracted stop" limit position must be set for the fabric tensioning function.

On delivery, the fabric stretching function is deactivated on tubular drives with a diameter of 35 mm, and is activated on tubular drives with diameters of 45 mm and 58 mm.

### Activating/deactivating the fabric tensioning function with a CentronicPLUS transmitter

	<p>Select the required receiver as described in the chapter Selection of the receiver for the setting mode [▶ 13].</p>
<p>▲</p> <p>● + ■ + ▼ 3s</p> <p>(M) 1x</p> 	<p>Open the shading solution to the Retract limit position.</p> <p>Then press the programming button again, and also the STOP and ▼ buttons for approx. 3 seconds.</p> <ul style="list-style-type: none"> <li>▷ The tubular drive confirms.</li> <li>▷ The transmitter confirms with a purple rotating light at the LED ring.</li> <li>▶ The fabric tensioning function is now activated/deactivated.</li> </ul>
<p>● 3s</p> 	<p>Then press the programming button for 3 seconds to change to normal mode.</p> <ul style="list-style-type: none"> <li>▶ The LED ring goes out.</li> </ul>

### Activating/deactivating the fabric tensioning function with a Centronic transmitter (master transmitter)







<p>▲</p>	<p>Open the shading solution to the Retract limit position.</p>
<p>● + ■ + ▼ 3s</p> <p>(M) 1x</p>	<p>Then press the programming button again, and also the STOP and ▼ buttons for approx. 3 seconds.</p> <ul style="list-style-type: none"> <li>▷ The tubular drive confirms.</li> <li>▶ The fabric tensioning function is now activated/deactivated.</li> </ul>

## Activating/deactivating the additional fabric tensioning function



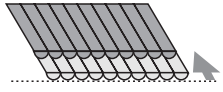



On delivery, the fabric tensioning function is deactivated.

### Activating the fabric tensioning function with a CentronicPLUS transmitter

**i** The fabric tensioning function is performed in the Extend limit position and at the programmed intermediate position.

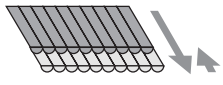



		Select the required receiver as described in the chapter Selection of the receiver for the setting mode [▶ 13].
		To activate it, move to the Extend limit position.
		Now move to the position where the fabric has the desired tension.
 3s	 	Press the programming button and, within the next 3 seconds, press the STOP and ▲ buttons at the same time and hold the buttons down for 3 seconds. <ul style="list-style-type: none"> <li>▶ The tubular drive confirms.</li> <li>▶ The transmitter confirms with a purple rotating light at the LED ring.</li> <li>▶ The fabric tensioning function is now active.</li> </ul>
 3s		Then press the ● button for 3 seconds to change to normal mode. <ul style="list-style-type: none"> <li>▶ The LED ring goes out.</li> </ul>

### Deactivating the fabric tensioning function with a CentronicPLUS transmitter

		Select the required receiver as described in the chapter Selection of the receiver for the setting mode [▶ 13].
		To deactivate it, move to the fabric tensioning limit position.
 3s	 	Press the programming button and, within the next 3 seconds, press the STOP and ▲ buttons at the same time and hold the buttons down for 3 seconds. <ul style="list-style-type: none"> <li>▶ The tubular drive confirms.</li> <li>▶ The transmitter confirms with a purple rotating light at the LED ring.</li> <li>▶ The fabric tensioning function is now deactivated.</li> </ul>
 3s		Then press the ● button for 3 seconds to change to normal mode. <ul style="list-style-type: none"> <li>▶ The LED ring goes out.</li> </ul>

### Activating the fabric tensioning function with a Centronic transmitter (master transmitter)

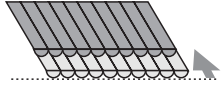
**i** The fabric tensioning function is performed in the Extend limit position and at the programmed intermediate position.

		To activate it, move to the Extend limit position.
		Now move to the position where the fabric has the desired tension.
 3s		Press the programming button and, within the next 3 seconds, press the STOP and ▲ buttons at the same time and hold the buttons down for 3 seconds. <ul style="list-style-type: none"> <li>▶ The tubular drive confirms.</li> <li>▶ The fabric tensioning function is now active.</li> </ul>





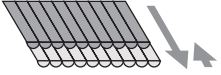

## Deactivating the fabric tensioning function with a Centronic transmitter (master transmitter)

▼		To deactivate it, move to the fabric tensioning limit position.
● + ■ + ▲ 3s	(M) 1x	Press the programming button and, within the next 3 seconds, press the STOP and ▲ buttons at the same time and hold the buttons down for 3 seconds.  ▶ The tubular drive confirms.  ▶ The fabric tensioning function is now deactivated.

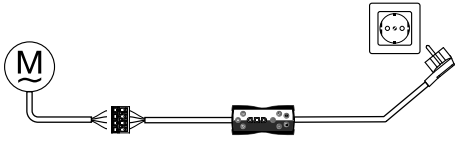
## Restoring the factory settings of the tubular drive

**i** The factory settings can only be restored via the universal programming unit (Item no. 4935 000 001 0).

	Connect the wires of the tubular drive to those of the same colour in the programming unit.	
	Connect the programming unit to the mains supply.	
	Now press and hold the button "Tubular drive with electronic limit switching and radio".	
▲ / ▼	Move the tubular drive to a point between the limit positions.	
	(M) 2x	Then press the "Delete transmitter" button for 10 seconds.  ▶ The tubular drive confirms.
▲ / ▼	Execute a short drive command.	
	(M) 2x	Now press the button "Delete limit position(s)".  ▶ The tubular drive confirms.  ▶ The factory settings of the tubular drive have now been restored.

## Local operation with a single button



**Only use a single button (normally open). Only connect one drive for each push-button. The length of cable between the tubular drive and the push-button must not exceed 20 m. The push-button must not be operated during the first five seconds after the mains voltage has been switched on.**

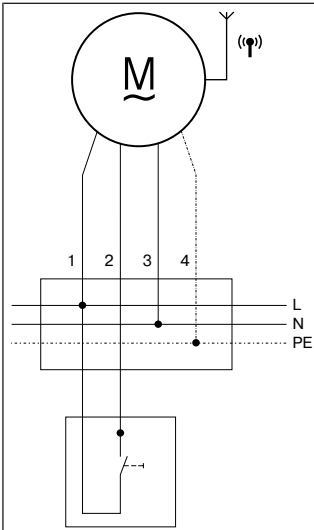

Button (normally open)

### Connection

1 = black	2 = brown
3 = blue	4 = green / yellow

### Button commands

Operation proceeds in this sequence: "Travel-Stop-Travel-in-the-opposite-direction-Stop".

< 1 second	Moves in maintained operation
> 1 second	Moves in dead-man mode
Double-tap < 1 second	Moves to the intermediate position (in alternation if both are programmed)

## Obstacle detection



### Caution

**Use of the drive's obstacle detection system as personal protection is not permitted. It has been designed exclusively to protect the sun protection system from being damaged.**

If the drive is correctly installed, it switches off when it detects obstructions or fabric faults and tries to run past the obstruction a second time. If this fails, the drive switches off after the third attempt. The total number of attempts to complete a travel that has been started to the respective limit position is limited to 10 (distributed over several obstruction locations).

If reversing is interrupted, a further drive command is only possible in the direction of reversing. Move the fabric without interruption until the tubular drive stops automatically. It is now possible to travel in both directions again.

## Disposal



The crossed-out bin symbol on the product indicates that the device is subject to mandatory disposal separate from household waste. This product must be handed over to a collection point for electrical and electronic equipment at the end of its service life. The packaging material must be disposed of properly.

## Maintenance

These drives are maintenance-free.

### Technical data dia. 35

Tubular drive	P5-20	P5-30	P9-16
Model	C12 PLUS		
Type	C PSF1 V1		
Rated torque [Nm]	5	5	9
Output speed [rpm]	20	30	16
Limit switch range	64 revolutions		
Supply voltage	230 V AC / 50 Hz		
Connected load [W]	115	115	110
Rated current consumption [A]	0.47	0.47	0.47
Operating mode	S2 4 min.		
Degree of protection	IP 44		
Min. tube inside diameter [mm]	37		
Frequency	868.3 MHz		
Emission sound pressure level [dB(A)]	≤ 70		

### Technical data dia. 45

Tubular drive	R8-17	R12-17	R20-17	R30-17	R40-17	R50-11
Model	C12 PLUS					
Type	C PSF1+ V1					
Rated torque [Nm]	8	12	20	30	40	50
Output speed [rpm]	17	17	17	17	17	11
Limit switch range	64 revolutions					
Supply voltage	230 V AC / 50 Hz					
Connected load [W]	100	110	160	205	260	240
Rated current consumption [A]	0.45	0.50	0.75	0.90	1.15	1.10
Operating mode	S2 4 min.					
Degree of protection	IP 44					
Min. tube inside diameter [mm]	47					
Frequency	868.3 MHz					
Emission sound pressure level [dB(A)]	≤ 70					



## Technical data dia. 58

Tubular drive	L50-17	L60-11	L60-17	L70-17
Model	C12 PLUS			
Type	C PSF1+ V1			
Rated torque [Nm]	50	60	60	70
Output speed [rpm]	17	11	17	17
Limit switch range	64 revolutions			
Supply voltage	230 V AC / 50 Hz			
Connected load [W]	315	265	380	430
Rated current consumption [A]	1.40	1.20	1.75	1.90
Operating mode	S2 4 min.			
Degree of protection	IP 44			
Min. tube inside diameter [mm]	60			
Frequency	868.3 MHz			
Emission sound pressure level [dB(A)]	≤ 70			

Tubular drive	L80-11	L80-17*	L120-11
Model	C12 PLUS		
Type	C PSF1+ V1		
Rated torque [Nm]	80	80	120
Output speed [rpm]	11	17	11
Limit switch range	64 revolutions		
Supply voltage	230 V AC / 50 Hz		
Connected load [W]	310	470	435
Rated current consumption [A]	1.40	2.10	1.90
Operating mode	S2 4 min.		
Degree of protection	IP 44		
Min. tube inside diameter [mm]	60		
Frequency	868.3 MHz		
Emission sound pressure level [dB(A)]	≤ 70		

\*) This tubular drive is not yet available.

## Error messages

 10x	<p>The tubular drive is blocked.</p> <ul style="list-style-type: none"> <li>▶ The transmitter confirms with 10 red flashes of the LED ring.</li> </ul>
 5x	<p>The tubular drive is overheated.</p> <ul style="list-style-type: none"> <li>▶ The transmitter confirms with 5 red / yellow flashes of the LED ring.</li> </ul>
	<p>The tubular drive is not responding.</p> <ul style="list-style-type: none"> <li>▶ The transmitter confirms with red flashing of the LED ring.</li> </ul>

## What to do if...?

Problem	Remedy
Tubular drive does not move.	Program new transmitter.
	Bring transmitter within range of the tubular drive.
	Press drive or stop button on transmitter at least five times in the immediate vicinity of the tubular drive.
	Insert battery/batteries correctly in the transmitter or insert new battery/batteries.
	Check electrical connection.
	Thermal protection switch in tubular drive has tripped. Wait until the thermal protection switch in the tubular drive is reactivated.
Running direction on tubular drive cannot be set.	Delete limit positions (see relevant chapter Deleting limit positions) and reset the running direction.
Incorrect running direction after deleting limit positions.	Use the relevant transmitter or the direction switch on the tubular drive to change the direction of rotation.
Tubular drive stops arbitrarily; cannot be restarted in the same direction.	Tubular drive has detected an increase in load. Briefly run the curtain in the opposite direction, then continue in the desired direction.
	Tubular drive is overloaded. Use a higher-torque tubular drive.
	Delete limit positions, then reprogram limit positions.
During the programming run, the drive stops short of the limit position to be programmed.	For safety reasons, the drive reacts sensitively to sluggishness during the programming run, in order to prevent damage. Briefly run curtain DOWN and subsequently UP until you reach the upper limit position.
The LED ring lights up red when the receiver for the setting mode is selected.	Reduce distance from receiver.
	Check electr. connection of the receiver.
	Put the receiver into programming mode.
	Add the transmitter to the installation.
The required setting cannot be changed.	Make sure that the CentronicPlus transmitter is in setting mode.
The tubular drive travels in the ▼ direction in dead-man mode, i.e. stops after 5 s of travel in the ▼ direction.	<p>Check the sensor connection, tubular drive/radio receiver has a sensor signal loss.</p> <p>Bring sensor within range of the tubular drive/radio receiver.</p> <p>Check the voltage supply to the sensor.</p>

# Sample wiring diagram

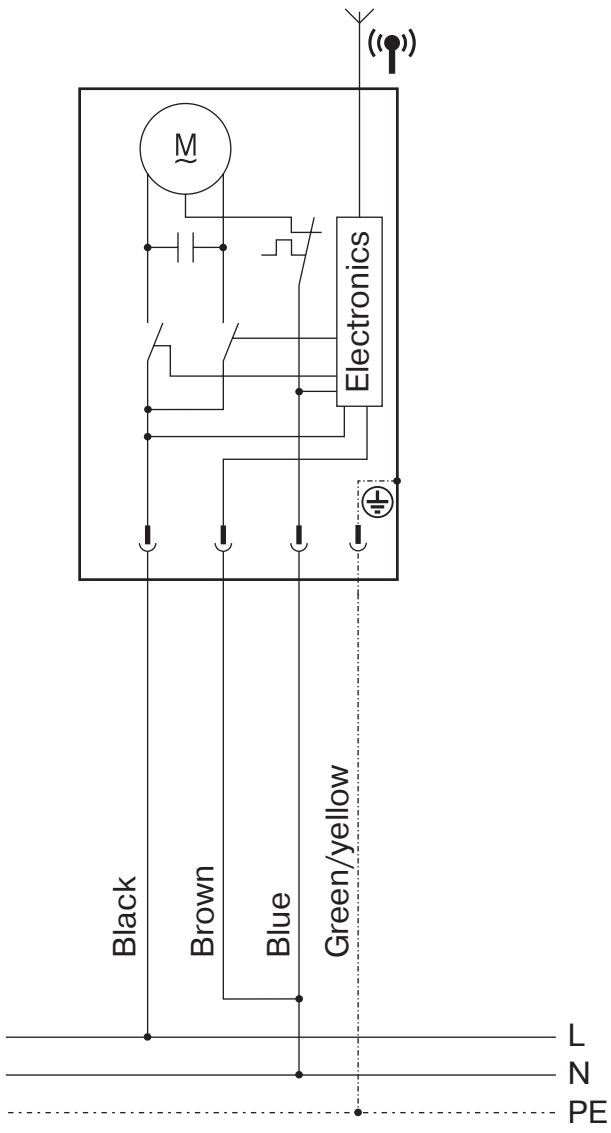

## Declaration of conformity

BECKER-ANTRIEBE GMBH  
Friedrich-Ebert-Str. 2 - 4  
35764 Sinn, Germany



**BECKER**

– Original –

### EU Declaration of Conformity

Document No.: **5100 310 075 0**

We hereby declare that the following product series

Product designation: **Tubular motor**

Type designation: **P5/16.., P5/20.., P5/30.., P9/16..,  
R8/17.., R12/17.., R20/17.., R30/17.., R40/17.., R50/11..,  
L50/17.., L60/11.., L60/17.., L70/17.., L80/11.., L80/17..,  
L100/11.., L120/11..**

Version: **C; P, R, S, E, O; F1...F99; +; A0...z9**

From serial number: **from 231600001**

complies with the applicable regulations of the following Directives:

**Directive 2006/42/EG (MD) L157, 09.06.2006**

**Directive 2014/53/EU (RED) L153, 22.05.2014**

**Directive 2011/65/EU (RoHS) L174, 01.07.2011**

Furthermore, the safety objectives of the **Low Voltage Directive 2014/35/EU** as per Appendix I No.1.5.1 of Directive 2006/42/EC have been met.

Applied standards:

**DIN EN 60335-1:2020  
EN 60335-2-97:2017**

**EN 300220-2:2018  
EN 301489-3:2019**

**EN 62479:2011**

**EN 14202:2004**

Authorised party for the compilation of the technical documentation:  
Becker-Antriebe GmbH, Friedrich-Ebert-Str. 2 - 4, 35764 Sinn, Germany

This declaration of conformity was issued:

Sinn, 13.04.2023  
Place, Date

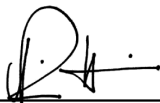
  
\_\_\_\_\_  
Maik Wiegelmann, Management

This declaration certifies compliance with the Directives cited but does not represent any assurance of characteristics. The safety warnings in the supplied product documentation must be observed!

CE Antriebe Bidi 5100 310 075 0 a\_en





**BECKER**

39 - en

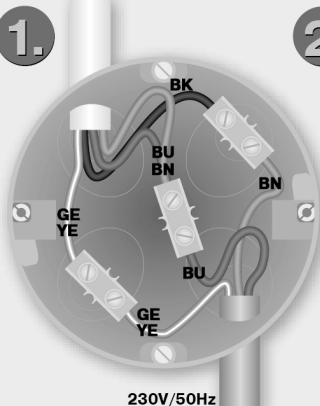

# Initial setup - tubular drives - Type C12 PLUS

## Add to the installation and assign selected channel

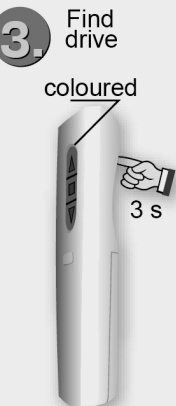

**1.** 

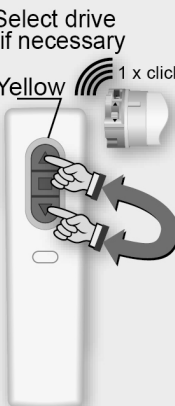

**2.** 

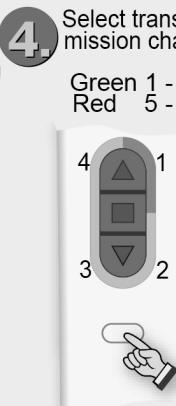
**3.** Find drive coloured  3 s

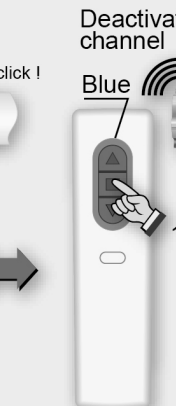

Select drive if necessary  Yellow  1 x click !

**4.** Select transmission channel  Green 1 - 4 Red 5 - 8



Activate channel  Green  1 x click ! 1 s

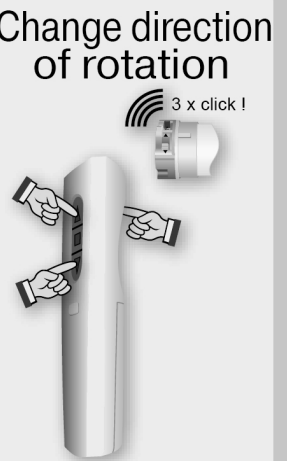

Deactivate channel  Blue  2 x click ! 1 s

## Programming in the setting mode

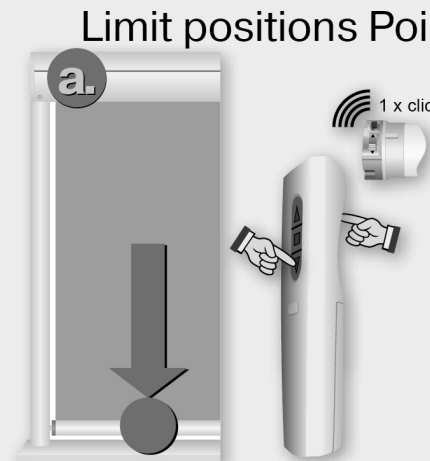

**5.** Switch on setting mode  light blue pulsing  1 x click ! 1 s

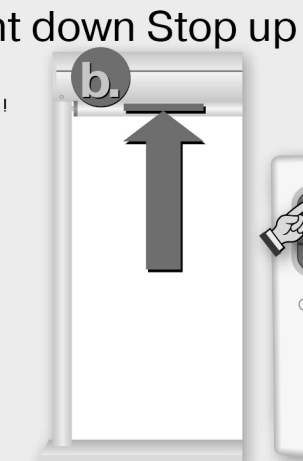

Change direction of rotation  3 x click !

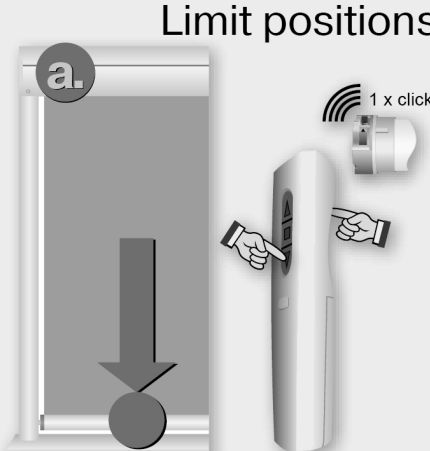

Limit positions Point down Stop up  a.  1 x click !

 b.  1 x click !

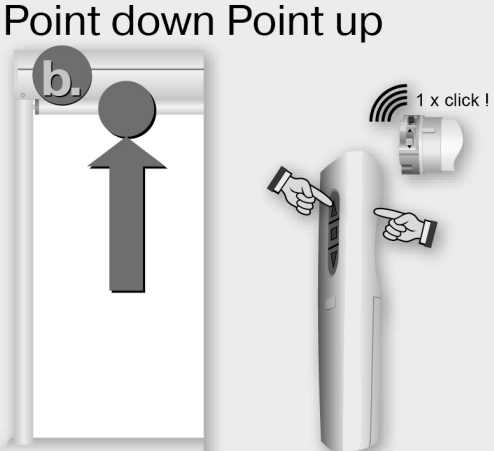
direct Switch on via step  **3.** + **5.**

Limit positions Point down Point up  a.  1 x click !

 b.  1 x click !

Delete limit positions   2 x click !

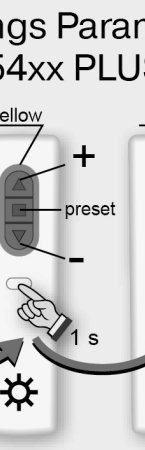
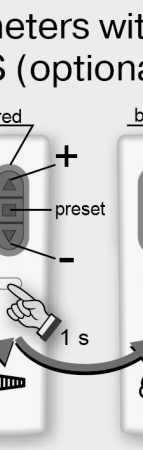

Settings Parameters with SWC54xx PLUS (optional)

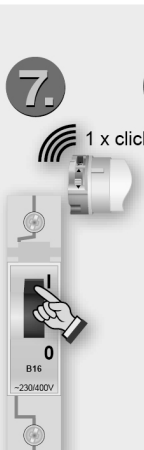

 3 s  1 s  1 s

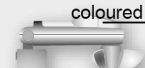
Exit setting mode  **6.** 3 s

Teach-in sensor  **7.** 1 x click !

 **8.** 3 s Find drive coloured  $\Rightarrow$  yellow 

 1 s Select drive yellow  1 x click !

 1 s Activate sensor green  1 x click !

 3 s Complete installation